

VE Electric Vibrator

The POWTEK VE rotary electric vibrator is a special electric motor with both ends of the shaft extended and fitted with eccentric weights. The housing is made of aluminum alloy up to size 660 and in ductile cast iron of high mechanical strength for all other frame sizes.

The combination of a drive shaft treated to withstand high stress and the specifically designed oversized bearings enable the units to perform continuous duty even at 100% force output.



VE3 3600 RPM Three-Phase

PERFORMANCE DATA								
MODEL	FORCE OUTPUT	UNBALANCE	HP	AMP DRAW 460 V	AMP DRAW 230 V	STARTUP CURRENT MULTIPLIER	FRAME	WEIGHT
	lbs	in -lbs	h.p.	Amps	Amps			lbs
VE3/36/95	114	0.34	0.15	0.20	0.40	3.0	0	9
VE3/36/95 XL	167	0.45	0.15	0.20	0.40	3.0	0	9
VE3/36/120	167	0.45	0.22	0.28	0.56	3.2	1	10
VE3/36/120 XL	208	0.56	0.22	0.28	0.56	3.2	1	11
VE3/36/250	297	0.81	0.25	0.32	0.64	3.0	1	11
VE3/36/400	398	1.08	0.28	0.34	0.68	3.0	1	12
VE3/36/660	653	1.94	0.34	0.60	1.2	3.7	2	18
VE3/36/1050	1511	4.44	0.72	0.85	1.7	4.6	3	42
VE3/36/1650	1815	5.30	0.85	1.0	2.0	4.0	4A	61
VE3/36/2200	2420	7.00	1.00	1.2	2.4	5.1	4B	65
VE3/36/2800	3200	8.8	1.75	1.8	3.6	4.8	6	76
VE3/36/3000	3507	10	2.01	2.1	4.2	6.0	15A	97
VE3/36/4000	4400	12	2.7	2.9	5.8	5.5	15B	101
VE3/36/5000	5500	15	3.2	3.5	7.0	5.4	20	161
VE3/36/7000	7040	19	5.4	5.6	11.2	5.2	30	218
VE3/36/10000	10560	29	6.7	7.1	14.2	4.9	60	299
VE3/36/12000	13200	36	11	12	24	5.4	70A	425
VE3/36/20000	19570	53	13	13.5	27	4.8	70B	517

TYPICAL APPLICATIONS

100-300 Lbs FORCE OUTPUT

Weigh batchers
Powder hoppers
Filling machines
Feeding tracks

400-1000 lbs FORCE OUTPUT

Chutes
Conveyors
Tables

1000-2000 lbs FORCE OUTPUT

Precast forms
Concrete tables
Railroad cars shakers
Aggregate and stone bins

3000+ lbs FORCE OUTPUT

Difficult products like
cinder, ore, lime, coal or clay



D I M E N S I O N S

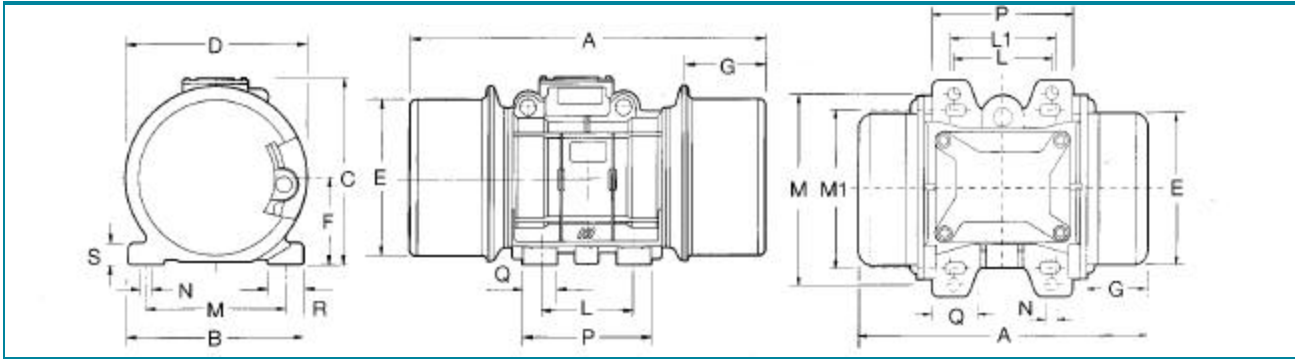

DIMENSIONS

MODEL	A	B	C	D	E	F	G	L	L ₁	M	M ₁	N	P	Q	R	S	BOLT HOLE NBR
VE3/36/95	7.65	4.92	4.80	3.42	3.23	1.81	1.38	2.44	-	3.86-4.17	-	0.35	3.89	1.18	1.22	0.32	4
VE3/36/95 XL	7.65	4.92	4.80	3.42	3.23	1.81	1.38	2.44	-	3.86-4.17	-	0.35	3.89	1.18	1.22	0.32	4
VE3/36/120	8.34	5.90	5.70	4.45	4.13	2.36	1.81	2.75	2.44-2.91	5.12	4.17	0.35	3.9	1.18	1.37	0.39	4
VE3/36/120 XL	8.34	5.90	5.70	4.45	4.13	2.36	1.81	2.75	2.44-2.91	5.12	4.17	0.35	3.9	1.18	1.37	0.39	4
VE3/36/250	8.34	5.90	5.70	4.45	4.13	2.36	1.81	2.75	2.44-2.91	5.12	4.17	0.35	3.9	1.18	1.37	0.39	4
VE3/36/400	8.34	5.90	5.70	4.45	4.13	2.36	1.81	2.75	2.44-2.91	5.12	4.17	0.35	3.9	1.18	1.37	0.39	4
VE3/36/660	10.24	6.54	7.28	6.30	5.12	2.95	1.97	3.54	3.54	4.92	5.51	0.51	4.72	1.18	1.57	0.47	4
VE3/36/1050	11.34	7.48	8.07	7.36	5.94	3.35	2.13	4.13		5.51		0.51	5.35	1.30	1.57	0.63	4
VE3/36/1650	13.98	8.27	9.29	8.50	7.13	3.98	2.80	4.72		6.70		0.67	6.30	1.57	1.69	0.79	4
VE3/36/2200	13.98	8.27	9.29	8.50	7.13	3.98	2.80	4.72		6.70		0.67	6.30	1.57	1.69	0.79	4
VE3/36/2800	14.75	9.28	9.29	8.50	7.13	3.98	2.80	3.94		7.87		0.67	6.30	1.57	1.69	0.95	4
VE3/36/3000	17.56	9.65	10.24	10.16	8.62	4.80	3.39	5.51		7.48		0.67	7.48	1.57	1.77	0.98	4
VE3/36/4000	17.56	9.65	10.24	10.16	8.62	4.80	3.39	5.51		7.48		0.67	7.48	1.57	1.77	0.98	4
VE3/36/5000	20.47	10.83	12.20	10.94	9.41	5.20	4.17	6.10		8.86		0.83	8.07	1.97	2.17	1.18	4
VE3/36/7000	21.26	12.80	13.54	12.80	11.14	6.18	4.02	6.14		10.08		0.91	8.66	2.17	2.36	1.38	4
VE3/36/10000	23.23	13.39	14.72	13.98	12.17	6.77	4.17	7.09		11.02		0.98	9.45	2.36	2.56	1.57	4
VE3/36/12000	25.12	15.35	16.26	15.67	13.66	7.52	4.13	7.87		12.6		1.11	11.02	2.95	3.07	1.77	4
VE3/36/20000	25.67	15.35	16.26	15.67	13.66	6.52	4.13	7.87		12.6		1.11	11.02	2.95	3.07	1.77	4

S I Z I N G A N D M O U N T I N G

WEIGHT OF THE MATERIAL ON THE BIN'S CONE (lbs)	FORCE OUTPUT NEEDED (lbs)	MINIMUM WALL THICKNESS	MINIMUM C-CHANNEL SIZE	MINIMUM PLATE THICKNESS
1000	100	12 gauge	3"	1/4"
2000	200	12 gauge	3"	3/8"
3000	300	11 gauge	4"	1/2"
5000	500	10 gauge	4"	1/2"
10000	1000	3/16"	5"	5/8"
50000	5000	1/2"	8"	1"

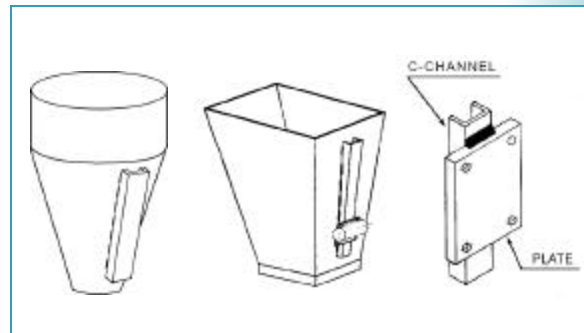

POWTEK

V I B R A T I O N T E C H N O L O G Y

3060 BRISTOL ROAD SUITE 236
 BENSALAM, PA 19020
 TEL: 215-752-9901 FAX: 215-702-1607
 powtek@powtekcorp.com
 www.powtekcorp.com

